



Water Waste Treatment  
Biogaz production  
Sludge volume reduction

- ✓ Design and proven reliability,
- ✓ Tanks from 1 000 to 6 000 m<sup>3</sup>
- ✓ Maximized life time (up to 95%)
- ✓ Reverse rotation for cleaning of the long fibres

*Reduces digestion time and increases production ...*

## Function :

Inside the digester, our mixer ensures the homogeneity of the substrates and the temperature of the sludge. It also avoids the formation of crust and sedimentary layers. LUMPP® mixers are also designed to maximize biogas recovery by installing a hydraulic guard that guarantees complete gas tightness. In addition, our mixer comply with ATEX standards to guarantee the safety of your installations and maximize the recovery of biogas. That's why the drive section is designed to operate 24 hours a day for over 50,000 hours of lifetime..

## 2 propellers, 2 different levels :

- The upper mobile is positioned to limit the formation of a crust and foam on the surface of the liquid.
- The lower mobile is positioned to ensure a good suspension of the particles and avoid the accumulation of these at the bottom of the tank.

## Key features:

- Hydraulic guard from 10 to 120 mbar
- Shaft length up to 25 m
- Propeller diameter up to 6,000 mm
- ATEX certification
- High-performance stirring mobiles
- Power up to 37 kW
- Sky gas biogas

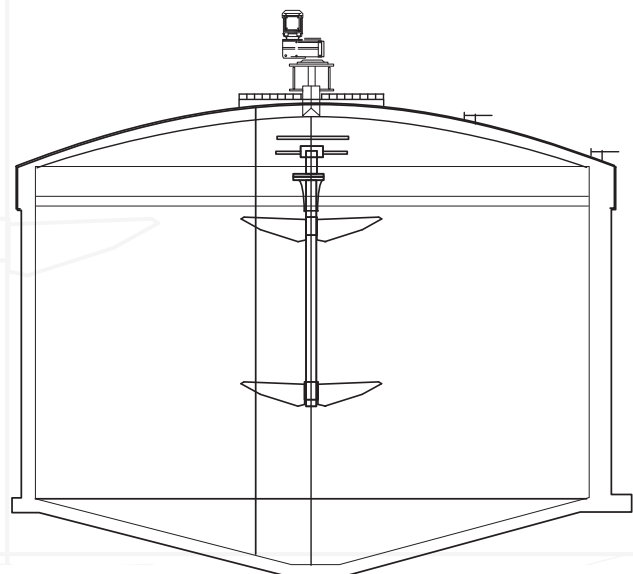

## **HASLER Group**

Headquarter  
Zi de l'abbaye  
38780 PONT-EVEQUE - France

Tel. +33 (0)4 74 16 11 50  
Fax +33 (0)4 74 16 11 55  
E-mail: sales.fr@hasler.group

All our addresses are on:  
[www.hasler.group](http://www.hasler.group)